

V300 Series 3 1/4" Frame Depth Casement (Project-Out)

V300 SERIES CASEMENT (PROJECT-OUT)

FEATURES

- ◇ **Commercial Framing System**
 - 3 1/4" main frame
- ◇ **Enhanced Design**
 - Mitered and welded corners
- ◇ **Glazing**
 - 1" insulated glass
- ◇ **Integral Nailing Fin**
- ◇ **Hardware**
 - Multi-point locking system with fold-down handle to avoid interference with window blinds
 - Heavy commercial 4-bar arms
 - Low profile flat lock
- ◇ **Screen**
 - Flex Screen
- ◇ **Colors**
 - White or Sandstone vinyl (interior/exterior)

BENEFITS

- ◇ The capacity to match exterior colors for unique project facades
- ◇ The ability to facilitate large sizes for taller and wider window openings

PERFORMANCE

- ◇ **Structural & Thermal** (test reports or thermal simulations available upon request)

Model	Casement (Project-Out)
NAFS Rating	CW-50
Structural Load P.S.F.	75.19
Air at 50 MPH (cfm/ft ²)	<0.30
Water (No Penetration) P.S.F.	7.5
U-Value (ranges based on multiple Low-E/Argon combinations)	0.23 - 0.28
SHGC (ranges based on multiple Low-E/Argon combinations)	0.11 - 0.42

Window test size: 36" x 78"

OPTIONS

- ◇ **Available Configurations**
 - Project-out casement
- ◇ **Muntin Choices**
 - Internal or simulated divided lites available
- ◇ **Limited Travel Hardware**
- ◇ **Screen**
 - Extruded aluminum screen frame with BetterVue™ mesh with WaterShed® technology
 - Extruded aluminum screen frame with aluminum wire mesh
 - Extruded aluminum screen frame with sunscreen mesh
 - Extruded aluminum screen frame with stainless steel 0.009" thickness mesh
- ◇ **Glazing**
 - Multiple Low-E and argon glazing choices
 - Triple glazing (Energy TG)
 - Capillary tubes
 - Wide variety of glazing, tinting and thickness options
- ◇ **Panning & Trim Choices**
 - Wide variety of panning, receptor and trim available
- ◇ **Mulling**
 - Wide variety of structural mulls
- ◇ **Colors**
 - High-performance Textured Black laminate (interior/exterior)
 - High-performance Textured Black laminate (exterior only with White vinyl or Textured Black laminate interior)
 - High-performance Textured Dark Bronze laminate (exterior only with White vinyl interior)
 - Twelve painted exterior colors (with White or Sandstone vinyl interior)
 - Unlimited custom painted exterior colors

Our products are tested to the standards of and certified by some of the foremost organizations in the fenestration industry.



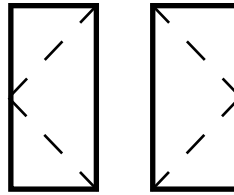

V300 SERIES CASEMENT

This document contains confidential and proprietary information intended for the private use of Quaker.
© 2016 Quaker Window Products Co., INC. All rights reserved.
Quaker reserves the right to change any/all designs without notice. Due to periodic re-certification requirements, result shown may vary.

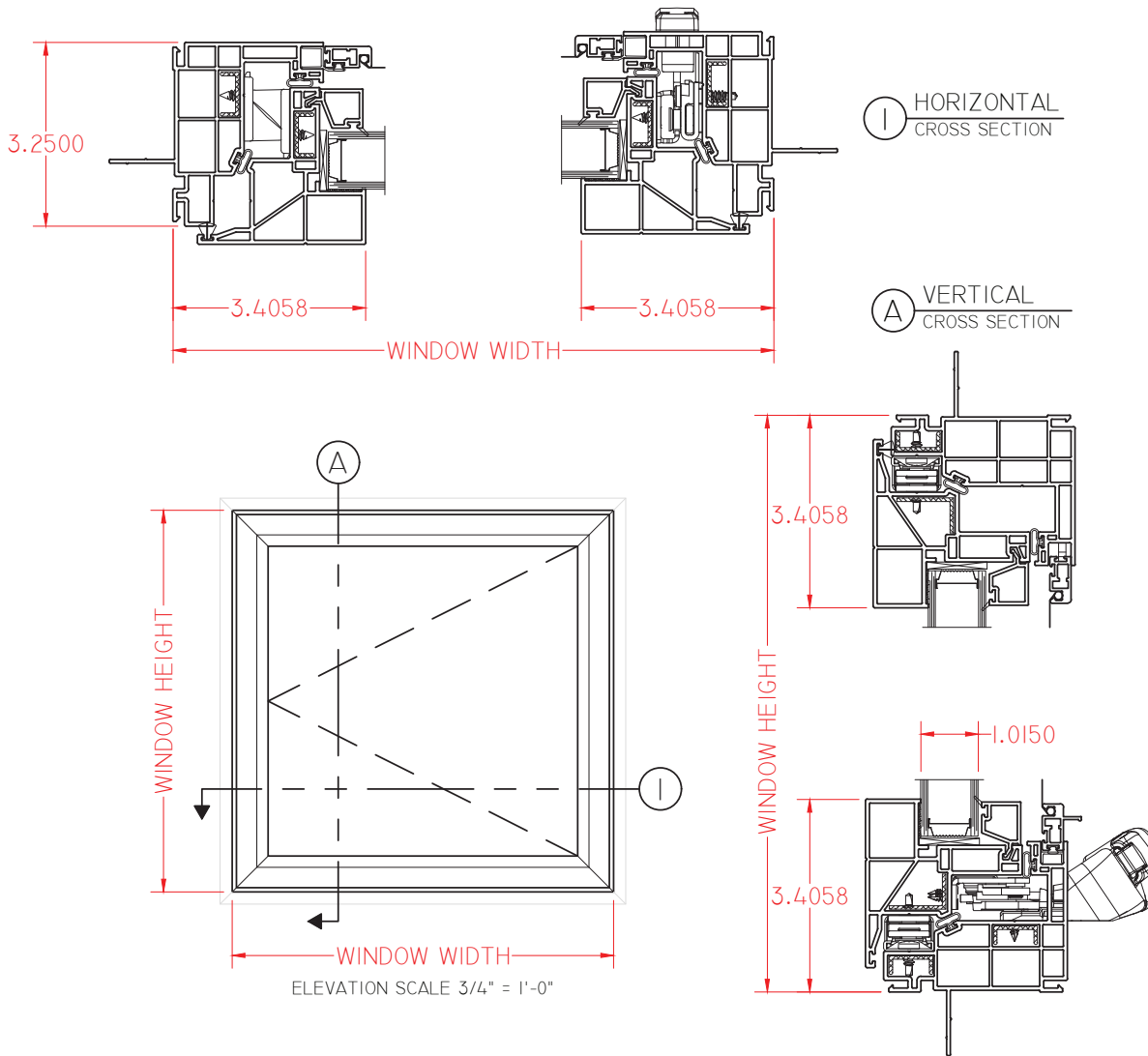

SCALE 1:3

Our products are tested to the standards of and certified by some of the foremost organizations in the fenestration industry.

